



# ACUNTO WOOD-FIRED CIRCOLARE 130

SERIES: ACUNTO NAPOLI OVENS



Standard Acunto Circolare 130 Model, shipped from Acunto factory

JOB NAME: \_\_\_\_\_

REFERENCE INVOICE #: \_\_\_\_\_

LEGS:  FIXED \_\_\_\_\_

CUSTOM TILE:  YES  NO \_\_\_\_\_

CUSTOM TILE DOCUMENT #: \_\_\_\_\_

CUSTOM LETTERING ON OVEN:  YES  NO \_\_\_\_\_

PRINT LETTERING: \_\_\_\_\_

NOTES: \_\_\_\_\_

- Model #130 ships with a complementary Carrara Marble counter-top.
- Acunto Ovens are fully cured at the Fiero Group facility before delivery.
- Gas-fired ovens must be special-ordered from Italy and require additional lead time.



BAKING SURFACE	OVEN OPENING	EXTERNAL WIDTH	EXTERNAL DEPTH

## FEATURES

The Acunto Circolare 130 oven is a hand-built Neapolitan brick oven which features a cast steel door opening 17" wide by 8.75" high. The refractory baking floor diameter is 51", lined with hand-made clay bricks to form a dome. An internal steel and cement structure reinforces the dome and shapes the oven base. A proprietary mixture of Neapolitan sand, volcanic rock and clay form a thick insulation, ensuring heat retention. The

oven is finished with red and white quartz paint and white Carrara marble countertops - the painted surfaces are prepared for tiling. The oven may be installed with a choice of permanent welded steel legs, removable steel legs, or placed on an existing structure without factory provided legs. Information about the addition of gas burners, custom tiling, or leg options can be found online at [www.fierogroup.com](http://www.fierogroup.com).

## THE ORIGINAL NEAPOLITAN OVEN

Over 125 years of artisan oven-building experience go into each Acunto Neapolitan brick oven. Endorsed by both the *Vera Pizza Napoletana Association* and the *Neapolitan Association of Pizzaioli*, it is the oven of choice for authentic Neapolitan pizza.

## OVEN PRODUCTION

**12" PIZZA CAPACITY:** 6 - 7 PIZZAS

**RECOMMENDED BAKING TIME:** 90 - 120 SECONDS

**RECOMMENDED OVEN FLOOR**

**TEMPERATURE RANGE:** 750°F - 900°F

**DAILY PREHEAT TIME:** 1 HOUR

## CUSTOM TILE & LETTERING AVAILABLE



1-year warranty on oven parts

**FIERO GROUP**  
601 N Main St, Brewster, NY 10509  
Email: [info@fierogroup.com](mailto:info@fierogroup.com)  
[www.fierogroup.com](http://www.fierogroup.com)

**844-OVEN-INC (844-683-6462)**  
Toll-free in USA  
(Hablamos Español,  
Falamos Português)

Listed to: UL 2162, NSF-4  
Commercial Wood-Fired  
Baking Ovens - Refractory Type;  
File#: MH48941



DOC#: GAC130-0118-1

REVISED WINTER 2018. As products continue to improve, spec sheets may change without notice. Please call Fiero Group for the latest specification sheet and for further details.

MADE IN ITALY



# ACUNTO WOOD-FIRED CIRCOLARE 130

SERIES: ACUNTO NAPOLI OVENS

## DETAILED SPECS

**WEIGHT:**  
**6,175 LB**

(Without legs and marble counter-tops)

We make every effort to provide accurate information regarding manufacturer's reported dimension information. Please note that due to the artisan nature of the manufacturing process, from time to time, product sizing and ship weight may vary slightly.

**FRONT ELEVATION**

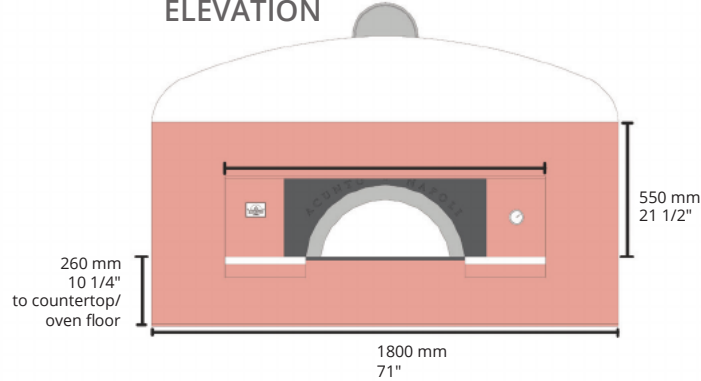

**PLAN VIEW**

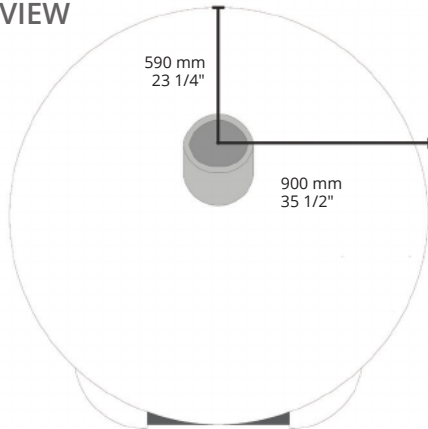

**RIGHT ELEVATION**

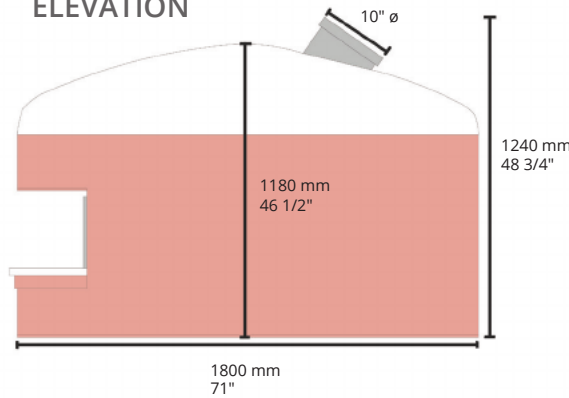

## LEGS

**Fixed:**  
4 3/4" x 4 3/4" footprint per leg



## CLEARANCES

Minimum clearance of the oven to combustible materials are as follows:

**Top: 18" (457 mm)**

**Back & Sides: 1" (25 mm)**

- Maintain required air space clearance between oven and combustible enclosure.
- Do not fill required air space with insulation or other materials.
- Non-combustible flooring must extend out at least 36" from oven opening and at least 30" to each side of the opening.

## VENTILATION REQUIREMENTS

Direct connection as a natural draft, grease-rated chimney system per NFPA 96 and UL 2162 is recommended. If the duct run exceeds 20 feet or incorporates a 90° elbow, a UL 705 & UL 762 listed rooftop exhaust fan shall be installed to ensure adequate pressure within the duct. A Listed Type 1 exhaust hood, or one constructed in accordance with all relevant local and national

codes (NFPA 96), may also be installed above the oven in instances where a natural/power draft chimney system is otherwise impossible. See "Ventilation Document - Acunto" for details.

**Operational airflow:** 200 CFM  
**Static Pressure at Flue Collar:**  
0.05 in H<sub>2</sub>O

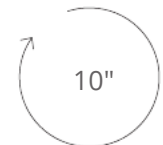

**FLUE COLLAR CONNECTION DIAMETER (INTERNAL)**

**FIERO GROUP**  
601 N Main St, Brewster, NY 10509  
Email: info@fierogroup.com  
www.fierogroup.com

**844-OVEN-INC (844-683-6462)**  
Toll-free in USA  
(Hablamos Español,  
Falamos Português)

Listed to: UL 2162, NSF-4  
Commercial Wood-Fired  
Baking Ovens - Refractory Type;  
File#: MH48941



DOC#: GAC130-0118-1

REVISED WINTER 2018. As products continue to improve, spec sheets may change without notice. Please call Fiero Group for the latest specification sheet and for further details.

MADE IN ITALY



# ACUNTO GAS & ELECTRICAL REQUIREMENTS DOCUMENT

SERIES: ACUNTO NAPOLI OVENS



Acunto Angolare



Acunto Circolare



Acunto Vesuvio

## GAS REQUIREMENTS

*(Only for gas-fired configurations - does not apply to wood-fired ovens.)*

*This equipment may be used with LP gas or natural gas.*

CONNECTION SIZE:	3/4" Male threaded			
GAS PRESSURE:	LP GAS		NATURAL GAS	
	11-14 in H <sub>2</sub> O		5.5 - 14 in H <sub>2</sub> O	
ORIFICE SIZE:	●	○	●	○
	#30		#5	
HOURLY BTU INPUT RATING:	28,000 Btu/Hr	140,000 Btu/Hr	28,000 Btu/Hr	140,000 Btu/Hr

● MINIMUM BTU

○ MAXIMUM BTU

*(Burner uses an automatic modulation control system that adjusts BTU according to need.)*

- Gas-fired ovens must be special-ordered from Italy and require additional lead time.
- Acunto Ovens are fully cured at the Fiero Group facility before delivery.

## ELECTRICAL REQUIREMENTS

VOLTAGE: 120V	CURRENT: 1.5A	FREQUENCY: 60Hz	PHASE: 1-Phase
---------------	---------------	-----------------	----------------

*Supplied with a NEMA 5-15 type grounded plug*

FIERO GROUP  
 601 N Main St, Brewster, NY 10509  
 Email: [info@fierogroup.com](mailto:info@fierogroup.com)  
[www.fierogroup.com](http://www.fierogroup.com)

844-OVEN-INC (844-683-6462)  
 Toll-free in USA  
 (Hablamos Español,  
 Falamos Português)

Listed to: UL 2162, NSF-4  
 Commercial Wood-Fired  
 Baking Ovens – Refractory Type;  
 File#: MH48941

