



# M51: TABLE TOP DOUGH SHEETER



SERIES: FIERO GROUP APPLIANCES



REFERENCE INVOICE #:

## THE PREFERRED DOUGH ROLLER

The Friulco M51 is a table top dough roller designed for the modern pizzeria. Over-engineered with thick AISI 300 & 400 series stainless steel, this dough roller is designed to be indestructible and easy for any employee to clean. Work with dough balls ranging from 6.3 to 35.3 ounces to achieve stretched diameters between 10" to 20". For more information on this product, please visit [www.fierogroup.com](http://www.fierogroup.com).

-  Dough balls are rolled and stretched at the set thickness and diameter in less than one second.
-  Patented balance mechanism which rotates the dough ball as it passes through the machine, ensuring a balanced dough stretch.
-  The steel rollers are coated in Delrin® food-grade acetal resin, ensuring they do not bend and provide superior stretching when in contact with the dough.

## DOUGH SPECIFICATIONS

Max Production Per Hour	Pizza Rolling Diameter	Dough Ball Weight
~3,000 Dough Balls	10" - 20"	6.3 - 35.3 Oz

## DIMENSIONS

Weight	Width	Depth	Height
198 lbs	25.2"	27.6"	34.6"

## ELECTRICAL REQUIREMENTS

Phase	Voltage	Current	Power
1 Phase	115 V / 60 Hz	9.73 A	750 W



Supplied with a standard NEMA 5-15P plug

## DIMENSIONAL DRAWING

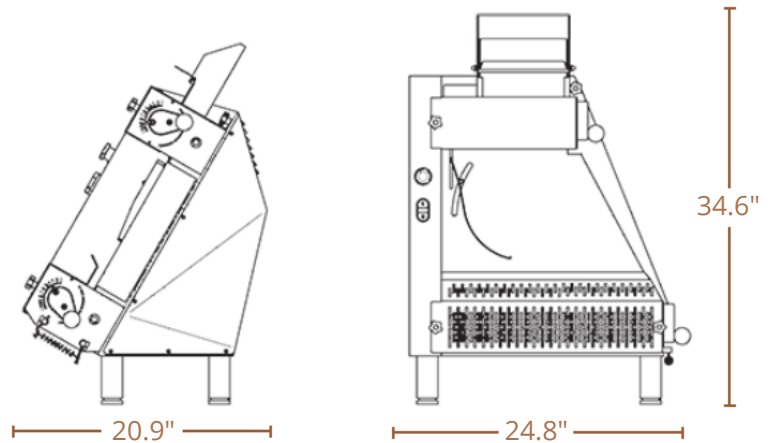

1 year limited warranty on parts. See warranty document for details.

FIERO GROUP  
601 N Main St, Brewster, NY 10509  
Email: [info@fierogroup.com](mailto:info@fierogroup.com)  
[www.fierogroup.com](http://www.fierogroup.com)

844-OVEN-INC (844-683-6462)  
Toll-free in USA  
(Hablamos Español,  
Falamos Português)

Listed to: ANSI/UL 763 &  
CAN/CSA-C22.2 No. 195 & NSF/ANSI-8  
Commercial Powered Food  
Preparation Equipment



DOC#: M51-11-19

REVISED FALL 2019. As products continue to improve, spec sheets may change without notice. Please call Fiero Group for the latest specification sheet and for further details.

MADE IN ITALY