



RPM 140X180 GAS

SERIES: PAVESI TRADITIONAL BRICK OVENS



Standard Pavesi
RPM 140x180

JOB NAME: _____

REFERENCE INVOICE #: _____

CUSTOM FACADE: YES NO

CUSTOM FACADE DOCUMENT #: _____

• Pavesi RPM 140x180 is constructed in a place by a certified Fiero Group Technician.

REFRACTORY MONOBLOCK FLOOR

The Pavesi RPM 140x180 features the world's only refractory commercial brick oven floor in one solid block.

TRADITION & TECHNOLOGY

The Pavesi RPM 140x180 is designed to preserve traditional Italian hearth oven dynamics with maximum consistency for high output.

VERSATILE & RELIABLE

The Pavesi RPM 140x180 design exceeds at holding a wide variety of temperatures to achieve almost any pizza size and style.



Approved by
the Association
of Neapolitan
Pizzaiuoli of
America

FEATURES

The Pavesi RPM 140x180 is a hand-built Italian hearth-style brick oven designed and manufactured in Modena, Italy. The solid, single piece refractory floor diameter is a 55" x 71" oval block, with a front-facing stone arch opening which allows access to the hearth at 23" wide by 11" tall. The internal refractory dome and single piece floor are sealed with a refractory cement and over-insulated with high quality asbestos-free ceramic blankets to ensure maximum heat retention. The oven structure is formed by a wrapped steel sheet painted "Rosso Corso" red, and sits on top of four circular dark grey steel legs. The oven is supplied with a single-flame powered gas burner for use as a primary oven heat source. The self-modulating gas burner monitors the oven floor temperature to adjust the BTU input for maximum efficiency and steady performance. Custom facade options can be found online at www.fierogroup.com.

BAKING SURFACE	OVEN OPENING	EXTERNAL WIDTH	EXTERNAL DEPTH

GAS REQUIREMENTS

This equipment may be used with LP gas or natural gas.

CONNECTION SIZE:	3/4" Male threaded			
	LP GAS		NATURAL GAS	
GAS PRESSURE:	11-14 in H ₂ O		5.5 - 14 in H ₂ O	
	●	○	●	○
ORIFICE SIZE:	#30		#5	
HOURLY BTU INPUT RATING:	28,000 Btu/Hr	140,000 Btu/Hr	28,000 Btu/Hr	140,000 Btu/Hr

● MINIMUM BTU ○ MAXIMUM BTU

(Burner uses an automatic modulation control system that adjusts BTU according to need.)

OVEN PRODUCTION

12" PIZZA CAPACITY: 13 - 15 PIZZAS

RECOMMENDED BAKING TIME: 90 - 240 SECONDS
(DEPENDING ON PIZZA STYLE)

RECOMMENDED OVEN FLOOR

TEMPERATURE RANGE: 600°F - 900°F

(DEPENDING ON PIZZA STYLE)

DAILY PREHEAT TIME: 75 MINUTES

CUSTOM FACADE OPTIONS



TILE



STUCCO

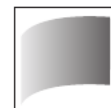

METAL WRAP

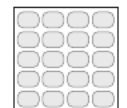

BRICK

(Please circle one. Depending on your preference, a custom facade worksheet will be sent to you)

FIERO GROUP
601 N Main St, Brewster, NY 10509
Email: info@fierogroup.com
www.fierogroup.com

844-OVEN-INC (844-683-6462)
Toll-free in USA
(Hablamos Español,
Falamos Português)

Listed to: UL 2162-ULC/ORD C2162,
ANSI Z83.11-CSA 1.8, & NSF-4 for
Commercial Wood Fired and
Gas Fired Cooking Equipment



DOC#: RPM140X180-1218

REVISED FALL 2018. As products continue to improve, spec sheets may change without notice. Please call Fiero Group for the latest specification sheet and for further details.

MADE IN ITALY



RPM 140X180 GAS

SERIES: PAVESI TRADITIONAL BRICK OVENS

DETAILED SPECS

WEIGHT:
3,460 LB

We make every effort to provide accurate information regarding manufacturer's reported dimension information. Please note that due to the artisan nature of the manufacturing process, from time to time, product sizing and ship weight may vary slightly.

FRONT ELEVATION

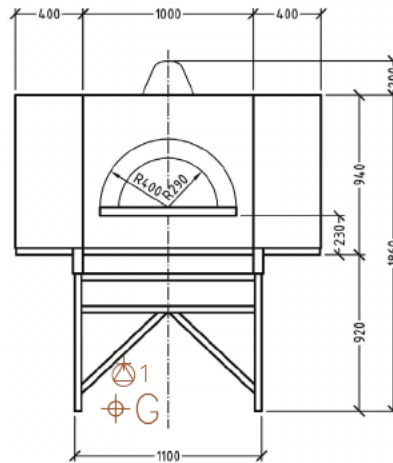

PLAN VIEW

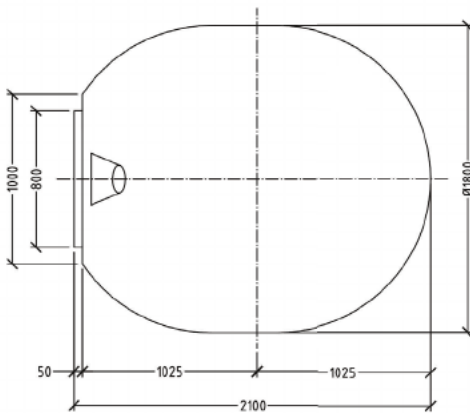

RIGHT ELEVATION

Pictured:
Left Gas
Disposition

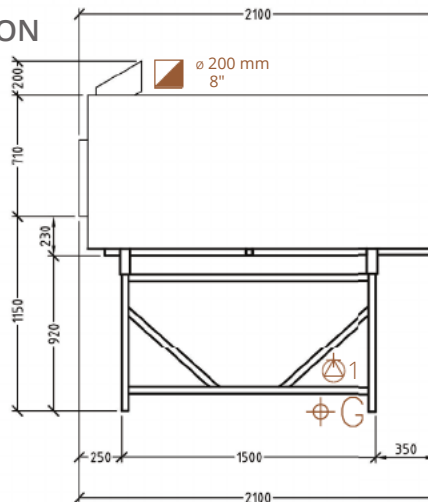

KEY

	Gas Burner Electrical Connection
	Gas Connection
	Flue Collar Exhaust Connection

All measurements listed in millimeters

CLEARANCES

Minimum clearance of the oven (built-in or standalone) to combustible materials are as follows:

Top: 14" (356 mm)
Back & Sides: 1" (25 mm)

- Non-combustible flooring must extend out at least 36" (914 mm) from oven opening and at least 30" (762 mm) to each side of the opening.
- Do not fill required air space with insulation or other materials.

VENTILATION REQUIREMENTS

Direct connection as a natural draft, grease-rated chimney system per NFPA 96 and UL 2162 is recommended. If the duct run exceeds 20 feet or incorporates a 90° elbow, a UL 705 & UL 762 listed rooftop exhaust fan shall be installed to ensure adequate pressure within the duct. A Listed Type 1 exhaust hood, or one constructed in accordance with

all relevant local and national codes (NFPA 96), may also be installed above the oven in instances where a natural/power draft chimney system is otherwise impossible. See "Ventilation Document - Pavesi" for details.

Operational airflow: 150-200 CFM
Static Pressure at Flue Collar: 0.05 in H₂O

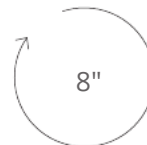

FLUE COLLAR
CONNECTION
DIAMETER
(EXTERNAL)

ELECTRICAL REQUIREMENTS

- 120 VAC, 1.2 A, 60 Hz
- Plug connection is a NEMA 5-15P Plug.

WARRANTY INFORMATION

10 year limited warranty on internal refractory parts, 1 year limited warranty on electrical, gas and other components. See warranty document for details.

FIERO GROUP
601 N Main St, Brewster, NY 10509
Email: info@fierogroup.com
www.fierogroup.com

844-OVEN-INC (844-683-6462)
Toll-free in USA
(Hablamos Español,
Falamos Português)

Listed to: UL 2162-ULC/ORD C2162,
ANSI Z83.11-CSA 1.8, & NSF-4 for
Commercial Wood Fired and
Gas Fired Cooking Equipment

